

LOWER FLOOR
MODEL 2A

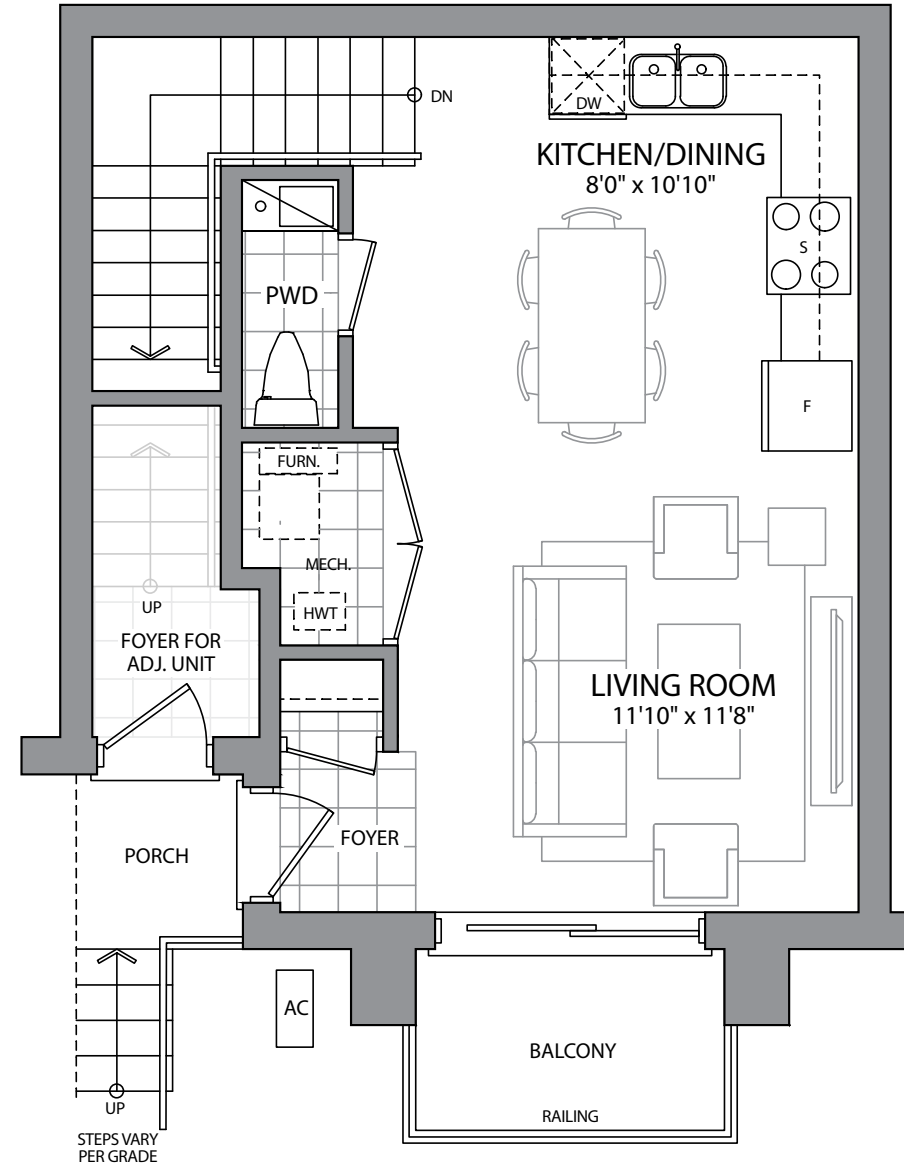

GROUND FLOOR
MODEL 2A

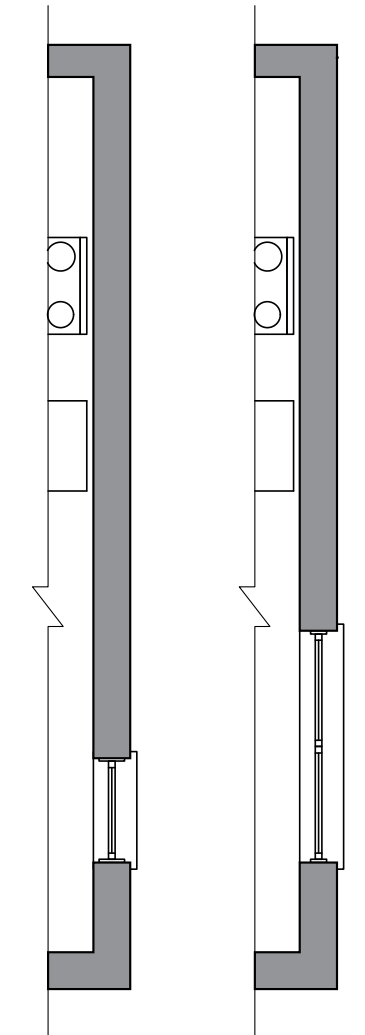

PART. GROUND FLOOR
MODEL 2AE

PART. GROUND FLOOR
MODEL 2A-E2

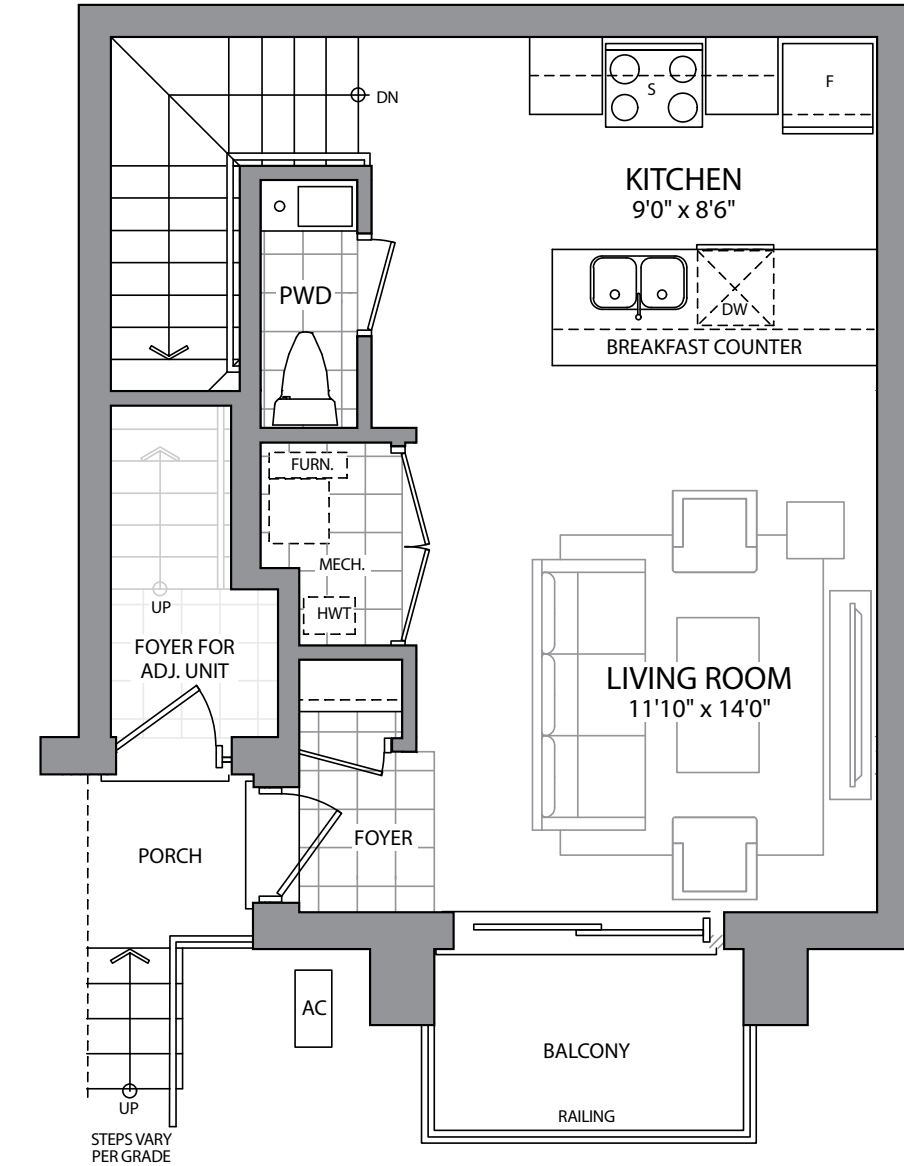

ALT. GROUND FLOOR
MODEL 2A

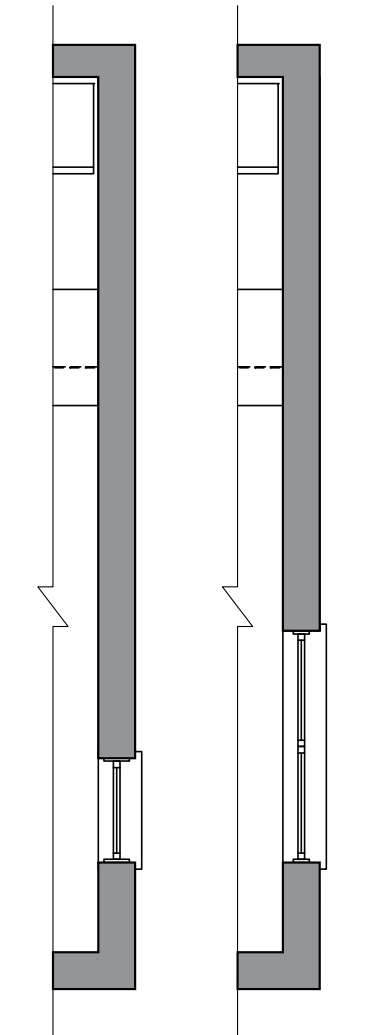

PART. ALT. GROUND FLOOR
MODEL 2AE

PART. ALT. GROUND FLOOR
MODEL 2A-E2



All plans and dimensions are approximate and subject to change at the discretion of the Vendor. Landscaping and park layout is artist's concept only. E.&O.E. March 2022